

## HD250-M58-A Kit



### Kit Contents:

1. Hardware (Screws, "L" Brackets, Metal Strap)
2. Rubber Boot for Cap.
3. Instructions

<b>Ballast Type:</b>	Magnetic	<b>Starting Method:</b>	Regular Start
<b>Lamp Type:</b>	Metal Halide	<b>Input Voltage:</b>	120/277/347
<b>Input Frequency:</b>	60Hz	<b>Recommended Fuse:</b>	8/3/3
<b>ANSI Code:</b>	M58/H37	<b>Rated Lamp Watts:</b>	250W
<b>Circuit Type:</b>	CWA	<b>Insulation Class:</b>	H (180°C)
<b>Power Factor:</b>	0.90	<b>Input Watts:</b>	295W
<b>Open Circuit Volts:</b>	280-350V	<b>Min Start Temp (°F/°C)</b>	-20/-30
<b>Nom. Open Circuit Voltage:</b>	350V	<b>Warranty:</b>	Two Years

## ELECTRICAL SPECIFICATIONS

Input Volts	Input Current (Amps)			Input Volts at Lamp Dropout	UL1029 Coil Temp. Code	Regulation		Short Circuit Current		
	Operating	Open Circuit	Starting			Line Volts	Lamp Watt	Secondary Current	Input Current	
120	2.50	2.10	2.20	60	E	+/-10%	250 +/-10%	2.25-2.75	1.30	2.10
277	1.05	0.90	1.00	138	F				0.50	0.90
347	0.85	0.75	0.80	174	F				0.40	0.80

## REGULATORY COMPLIANCE

- Complies with ANSI Standards
- CSA Certified
- cRUus Listed
- UL Class H Thermal Insulation



ULTRASAVE LIGHTING LTD.

12-140 AMBER STREET, MARKHAM, ON L3R 3J8

TEL 905.940.0888

FAX 905.940.0338

WWW.ULTRASAVE.CA

## PHYSICAL CHARACTERISTICS

### WIRING DIAGRAM

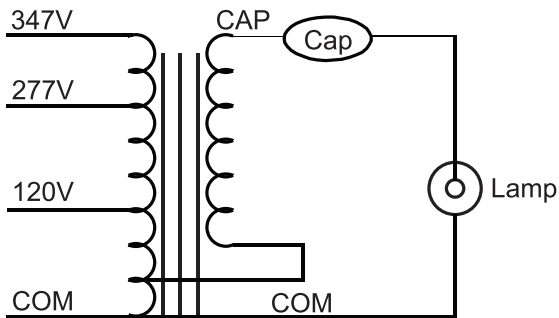

### DIMENSIONS

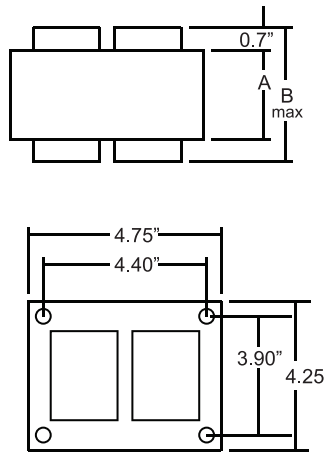

A	1.57"
B	3.10"
Lead	12"
Weight	9 lbs
Ballast to Lamp Distance	10'

## CAPACITOR

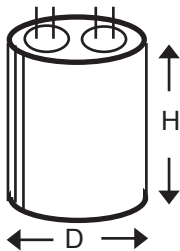

Temp. Rating	100°C
Capacitance	15uF +/-3%
Volts (min)	400 VAC
Type	Oil Filled
Height	3.25"
Diameter	1.75"

## ORDERING INFORMATION

Model #	Box	Box Weight	Box Measurement LxWxH	Bulk	Bulk Weight	Bulk Measurement LxWxH
HD250-M58-A	1	9.50 lbs	8.00"x4.75"x4.75"	168	1,719.50 lbs	39.75"x41.50"x25.00"

### ULTRASAVE LIGHTING LTD.

12-140 AMBER STREET, MARKHAM, ON L3R 3J8

TEL 905.940.0888

FAX 905.940.0338

WWW.ULTRASAVE.CA