



PART NUMBER:	DATE:
PROJECT #:	TYPE:
PREPARED BY:	



PART NUMBER:

FBEMH150-120-P

ELECTRONIC HID BALLAST

APPLICATIONS:

- **Retail:** Malls, Shopping Centers, Stores, etc.
- **Hospitality:** Restaurants, Hotels, etc.
- **Commercial:** Offices, Show Rooms & Display Areas

Fusion Electronic HID Ballasts are designed to perform to the highest standards and conform to and meet all applicable ANSI, FCC, UL & CSA requirements and provide energy efficient HID system solutions for numerous applications and for use in various fixture designs including recessed and surface mounted as well as specialty fixtures. All Fusion electronic ballasts have a 5 year limited warranty providing peace of mind for the user.

WIRING DIAGRAM:

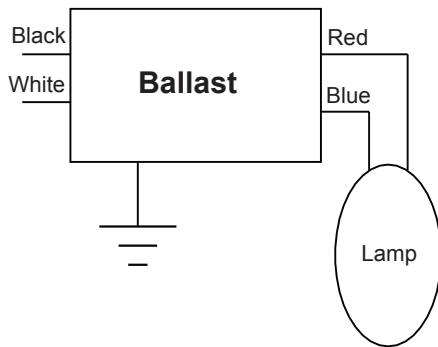

FEATURES & BENEFITS:

- Programmed cold start
- 150 watt Metal Halide lamp types
- 120/277V input voltage
- Minimum starting temperature -22 °F / -30 °C
- <10% THD and >0.99 PF
- 90 °C case temperature rating
- Lightweight and small ballast housing with side leads
- Lamp end-of-life protection circuitry
- 5 Year Warranty
- RoHS Compliant
- Meets ANSI Standard C62.41
- Meets FCC Part 18 Class A for EMI/RFI (non consumer limits)
- cULus Listed (Calls P, Type 1 Outdoor, Type HL)

BALLAST DIMENSIONS:

(L) 6.81" x (W) 3.58" x (H) 1.73"

APPROVALS



ORDERING INFORMATION:

PART NUMBER	DESCRIPTION	UNIT QTY	CASE QTY	CASE DIMENSIONS	CASE WEIGHT
FBEMH150-120-P	Fusion 150W Mhp 120-277V E-Ballast	1	20	19.7" x 8.3" x 9.8" - 50.0 x 21.1 x 24.9 mm	50.6 lbs - 23.0 kgs

TECHNICAL SPECIFICATIONS:

LAMP TYPE	# OF LAMPS	LAMP WATTS	MIN. START TEMP	INPUT CURRENT (Amps)	INPUT WATTS	MAX. THD%	POWER FACTOR	BALLAST FACTOR	BEF
M81	1	150	-22°C / -30°F	1.32	158	10	0.99	1.00	0.63
M102									
M142									